

The Hall® Maxi-Driver™ Pneumatic System Instruction Manual



Proprietary Information

This manual contains information deemed proprietary to Linvatec Corporation. The information contained herein, including all of the designs and related materials, is the sole property of Linvatec and/or its licensors. Linvatec and/or its licensors reserve all patent, copyright and other proprietary rights to this document, including all design, manufacturing methodology and reproduction.

This document, and any related materials, is confidential and is protected by copyright laws and shall not be duplicated, transmitted, transcribed, stored in a retrieval system, or translated into any human or computer language in any form or by any means, electronic, mechanical, magnetic, manual or otherwise, or disclosed to third parties, in whole or in part, without the prior express written consent of Linvatec.

Linvatec reserves the right to revise this publication and to make changes from time to time in the contents hereof without obligation to notify any person of such revision or changes, unless otherwise required by law.

Linvatec, Hall, and Maxi-Driver are trademarks or registered trademarks of Linvatec Corporation.

© Linvatec Corporation 2001. All Rights Reserved. Printed in USA

Record the Model and Serial Numbers of the handpiece(s), and date received. Retain for future reference.

Handpiece Model No.	_____	Serial No	_____	Date	_____
Handpiece Model No.	_____	Serial No	_____	Date	_____
Handpiece Model No.	_____	Serial No	_____	Date	_____
Handpiece Model No.	_____	Serial No	_____	Date	_____

Table of Contents

Page

1.0 INTRODUCTION

1.1 Intended Use 1
1.2 General Warnings 1
1.3 Symbol Definitions 2
1.4 Pneumatic Handpiece (L100) 3

2.0 INSTALLATION and OPERATION

2.1 Power Source and Regulator Installation and Operation 4
2.2 Attachments and Accessories 8
 2.2.1 Connecting/Removing Attachments 9
 2.2.2 Automatic Pin Driver Attachment (L111) 9
 2.2.3 Oscillating Saw Attachment (L320A) 11
 2.2.4 Reciprocating Saw Attachment (L140A) 12
 2.2.5 Jacobs Chuck Attachment (L110) 13
 2.2.6 Trinkle Chuck Attachment (L112) 14
 2.2.6.1 Automatic Screwdrivers for the Trinkle Chuck
 Attachment (D520/D524) 15
 2.2.7 Hudson Chuck Attachment (L113) 17
 2.2.8 Hudson Reamer Drive Attachment (L150) 18
 2.2.9 Zimmer Chuck Attachment (L115) 19
 2.2.10 Zimmer Reamer Drive Attachment (L153) 20
 2.2.11 ASIF/AO Twist Drill Chuck Attachment (L513) 21
 2.2.12 ASIF/AO Flexible Chuck Attachment (L514) 22
 2.2.13 ASIF/AO Reamer Drive Attachment (L151) 23
 2.2.14 Aesculap Reamer Drive Attachment (L152) 24
 2.2.15 Aesculap Chuck Attachment (L515) 25

<u>Table of Contents</u>	<u>Page</u>
3.0 MAINTENANCE	
3.1 Cleaning and Sterilizing	28
3.1.1 Cleaning Precautions	28
3.1.2 Handpiece and Attachment Cleaning Instructions	28
3.1.3 Handpiece and Attachment Lubrication Instructions	29
3.1.4 Sterilization Information	30
3.1.4.1 Sterilization Warnings, Precautions and Notes	30
3.2 Troubleshooting	32
4.0 TECHNICAL SPECIFICATIONS	
4.1 Handpiece	38
4.2 System Environmental Requirements	38
5.0 CUSTOMER SERVICE and WARRANTY	
5.1 Customer Service	39
5.2 Handpieces, Attachments and Accessories	41
5.3 Linvatec® and Hall® Surgical Instrument Warranty	42



1.0 INTRODUCTION



It is recommended that personnel study this manual before attempting to operate, clean or sterilize the Hall® Maxi-Driver™ Pneumatic Instrument System. The safe and effective use of this equipment requires the understanding of and compliance with all warnings, caution notices and instructions marked on the product and included in this manual.

1.1 Intended Use









The Maxi-Driver Pneumatic Instrument System is designed to provide optimal speed and torque for large bone orthopedic surgery, including cutting, drilling, pinning, sawing, reaming and driving screws. The system attachments are completely interchangeable between the Maxi-Driver pneumatic, battery, and electric handpieces.

1.2 General Warnings

1. This equipment is designed for use by medical professionals completely familiar with the required techniques and instructions for use of the equipment. **Read and follow all warning and caution notices and instructions marked on the product and included in this manual.**
2. Eye protection is recommended when operating equipment. 
3. Use only associated Hall® Surgical and Linvatec® attachments and accessories (i.e., saw blades, bits, etc.).
4. Handle all equipment carefully. If any equipment is dropped or damaged in any way, return it immediately for service.
5. Prior to each use, perform the following:
 - Inspect all equipment for proper operation.
 - Ensure all attachments, accessories and hoses are correctly and completely attached to the handpiece.
 - Check all pneumatic equipment for any air or nitrogen leakage. If leakage is noticed, return for service.
 - Always inspect pneumatic hoses for signs of wear or damage. **Do not use worn or damaged hoses. Replace immediately.**
 - Always inspect for bent, dull or damaged blades or drill bits.  Do not attempt to straighten or sharpen. Do not use if damaged. After use, dispose of properly.

6. Oscillating and reciprocating saw blades, and bits are single-use only. Do not resterilize. After use, dispose of properly. 
7. Handpieces are factory sealed. Do not disassemble. 
8. Do not pressurize hoses until all fittings have been connected and checked.
9. Never operate pneumatic handpiece above 110 psi (7 kg/cm²) dynamic pressure unless an extension hose is added to the standard 10 foot hose. Excessive pressure may cause damage to the instrument and exert unusual stress on the hose.
10. The nitrogen regulator is only for use with pneumatically powered surgical devices.
11. Continually check all handpieces and attachments for overheating. Discontinue use and return equipment for service as necessary. Overheating of the bit or blade may cause damage to the bit or blade and may cause thermal necrosis.
12. Do not attach, insert or remove accessories or attachments while the handpiece is operating. **Place the handpiece safety to the appropriate safe position prior to installation or removal of items.**
13. After each use, thoroughly clean the handpiece and attachments (See “3.1 Cleaning and Sterilizing” on page 28).

1.3 Symbol Definitions

	Attention, consult accompanying documents.
	No user service recommended. Refer servicing to qualified Linvatec service personnel.
	Indicates product component should not be sterilized.
	Indicates product component should not be immersed in any type of fluid.
	Indicates handpiece should not be immersed in any type of fluid.
	Indicates product should not be oiled or lubricated.
	Single Use Only
	Eye Protection Required

Rx ONLY	Caution: Federal Law restricts this device to sale by or on the order of a physician
----------------	---

1.4 Pneumatic Handpiece (L100)

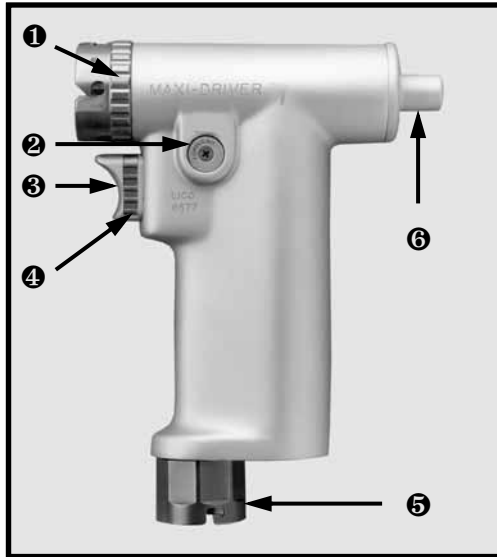

- ❶ **Attachment Collet-Lock** — Twist to release and remove attachments from the handpiece. It is not necessary to twist for insertion of attachment. Simply insert and push attachment to lock in place.
- ❷ **Direction Button** — Press this button inward to place the handpiece in the forward (clockwise) direction. Press in the opposite direction for reverse (counterclockwise).
- ❸ **Activation Trigger** — Used to activate the handpiece when the direction button is in either the forward or reverse position.
- ❹ **Safety Slide** — Slide the safety slide upward to place the handpiece in the safe, or non operative position. Slide downward to place the handpiece in an operating mode.

- ❺ **Hose Connector** — The air hose attaches here from the air supply tank. The connector swivels 360° to help eliminate hose binding.
- ❻ **Cannulation** — Used to stabilize long wires or pins.

2.0 INSTALLATION and OPERATION

2.1 Power Source and Regulator Installation and Operation

WARNING: Not for inhalation. Does not support life. For use with powered surgical devices only.

Research and experience have shown that water-pumped dry nitrogen is the ideal source for pneumatically-powered surgical instruments. Water-pumped dry nitrogen is 99.97% pure, and will not support combustion or corrosion. Compressed dry nitrogen is recommended as the pneumatic power source. It is available in standard cylinders.

Compressed dry nitrogen must meet the following specifications to ensure optimum safety for both patient and instrument.

Nitrogen Content: 99.97% pure, dry nitrogen.

Quality Assurance: To obtain the quality of gas needed, “water-pumped dry nitrogen, or liquid nitrogen, pumped dry” should be specified.

Nitrogen is readily available from gas supply houses in **H** cylinders holding slightly more than 300 cubic feet (8.50 cubic meters). Initial set-up costs are relatively inexpensive as compared to compressed air. Nitrogen can be placed in the operating room or in a storage area and piped into the operating room. Manifold systems are available to eliminate frequent tank changes.

CAUTION: Do not exceed 110 psi (7 kg/cm²) operating pressure unless a hose longer than the standard 10 ft. Air Hose (REF D201) or extension hose is used. Add an additional 1 psi for every extra foot of hose.

The Maxi-Driver pneumatic handpiece should be operated at 110 psi (7 kg/cm²) for maximum operating efficiency, and should be monitored by the operating pressure gauge of the regulator. Lower pressure setting can be set for lower speed and torque requirements. Pressure must be set with the instrument running to ensure proper operating pressure.

Never start a procedure if the operating pressure gauge indicates less than 500 psi (35.1 kg/cm²) in the tank. Never run the tank pressure below 200 psi (14.0 kg/cm²).

The tank should be thoroughly wiped off with disinfectant and draped prior to placement in the operating room. Always have the tank securely fastened to a stable object.

1. Prior to set-up in the operating room, open the tank valve (counterclockwise) slowly and allow enough gas to escape to blow out any debris that may have accumulated in the valve. Stay clear of the opening and the back of the tank during this procedure. Return the valve to the closed position.



2. Install the regulator with a 1 1/8 inch wrench.



NOTE: The threaded adaptor of the nitrogen regulator is designed to fit nitrogen fittings only. Incompatibility of the regulator and tank indicates a gas source other than nitrogen or an improper regulator for use with a nitrogen tank.

3. Once the regulator is securely installed, ensure the regulator knob is in the full off position by turning the regulator control knob counterclockwise. **SUDDEN PRESSURE EXERTED TO THE REGULATOR MAY CAUSE INTERNAL DAMAGE.**



4. Slowly turn the tank valve fully open (counterclockwise). This will allow nitrogen to pressurize the regulator.



5. Insert the male Schrader end of the hose into the female Schrader on the regulator with an upward thrust.



6. To connect the handpiece to the hose.
 - (a) Place the handpiece safety slide in the safe (up) position.



- (b) Before connecting the hose to the handpiece, ensure that the O-Ring on the end of the hose connector is in place. If damage is present, replace the O-Ring (REF 8016).
 - (c) Grasp the hose connector and insert it into the connector on the bottom of the handpiece.
 - (d) Twist the hose coupling to the right (clockwise) and slightly pull on the hose so the internal pins securely engage in the indentations.
 - (e) To remove the hose from the handpiece, reverse steps 6a and 6b.
7. With the safety slide still in the safe position, install the desired attachment and accessory at this time by referencing “2.2.1 Connecting/Removing Attachments” on page 9.
8. Operating pressure is established by gradually turning the regulator control knob clockwise. **ALWAYS establish the designated pressure on the operating pressure gauge with the instrument running.**



9. To operate the handpiece:
- (a) Release the safety by sliding the safety slide downward.
 - (b) Place the directional control button to the desired operating position, either forward (F) or reverse (R).
 - (c) Depress the trigger.

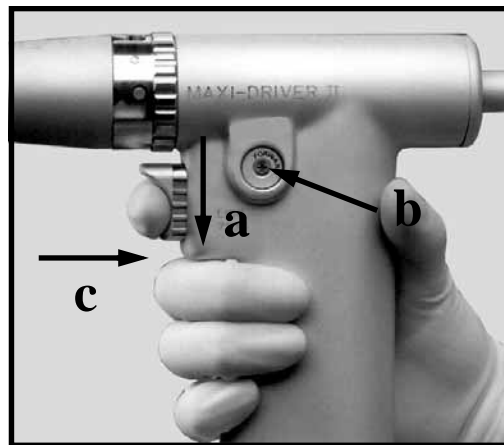

10. While, depressing the trigger, adjust the nitrogen regulator until the gauge indicates 110 psi.
11. Before removing the instrument from the regulator:
- (a) Close the tank valve by turning it clockwise.
 - (b) Activate the instrument to bleed off line pressure.
 - (c) Turn the pressure regulator knob counterclockwise until it stops.
 - (d) Turn the female Schrader to the right to disengage the male Schrader fitting.

- (e) The hose can then be removed from the connector. Hold the end of the hose securely when disengaging the male Schrader fitting to prevent possible damage to the diffuser.

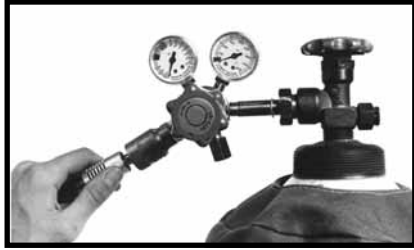

12. If the Hall Pneumatic Connector* is being used:

- (a) Locate the button marked “PRESS”.
- (b) Depress and hold the button until the audible release of residual gas is completed.



- (c) Release the button and remove the hose.
- (d) If the hose cannot be easily removed, depress the “PRESS” button again, release it and remove the hose.

* U.S. Patent 4,863,201

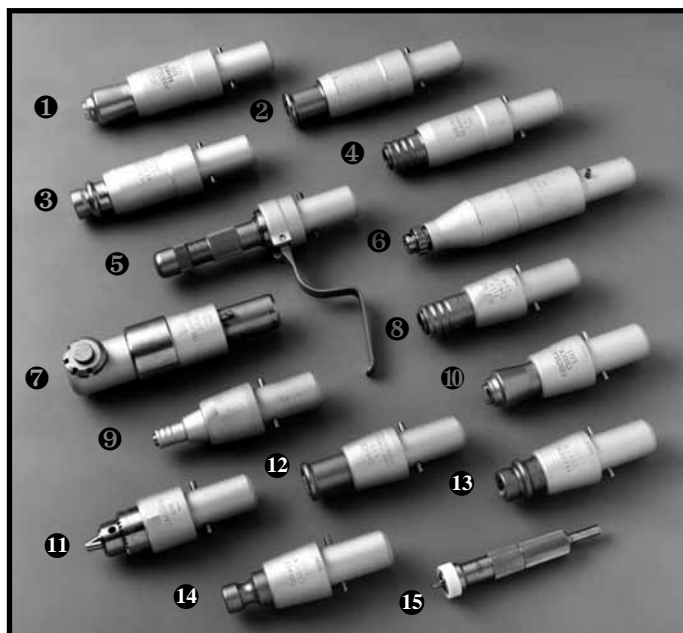

2.2 Attachments and Accessories

- ❶ Aesculap Reamer Drive Attachment (L152)
- ❷ Zimmer Reamer Drive Attachment (L153)
- ❸ Hudson Reamer Drive Attachment (L150)
- ❹ ASIF/AO Reamer Drive Attachment (L151)
- ❺ Automatic Pin Drive Attachment (L111)
- ❻ Reciprocating Saw Attachment (L140A)
- ❼ Oscillating Saw Attachment (L320A)
- ❽ ASIF/AO Chuck Attachment (L514)
- ❾ ASIF/AO Twist Drill Chuck Attachment (L513)
- ❿ Aesculap Chuck Attachment (L515)
- ⓫ Jacobs Chuck Attachment (L110)
- ⓬ Zimmer Chuck Attachment (L115)
- ⓭ Hudson Chuck Attachment (L113)
- ⓮ Trinkle Chuck Attachment (L112)
- ⓯ Automatic Screwdriver Attachments (D520/D524)

2.2.1 Connecting/Removing Attachments

All Maxi-Driver Handpiece attachments connect/disconnect in the same manner and are interchangeable between the battery and pneumatic handpieces. See pages 9 through 25 for attachment information.

1. To connect an attachment:
 - (a) Ensure the handpiece is in the safe position.
 - (b) Twist the lock/release collar to open the attachment receptacle and insert the attachment into the handpiece. Release the lock/release collar to secure the attachment to the handpiece.
 - (c) Ensure the attachment is secure by pulling it outward.

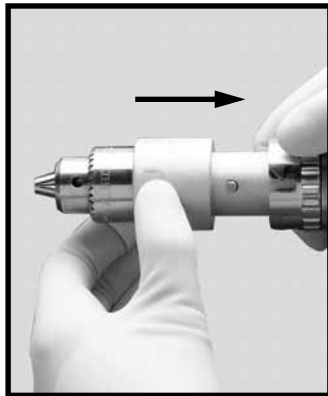

- (d) To remove the attachment, repeat steps 1(a) and 1(b), and pull out the attachment.

2.2.2 Automatic Pin Driver Attachment (L111)

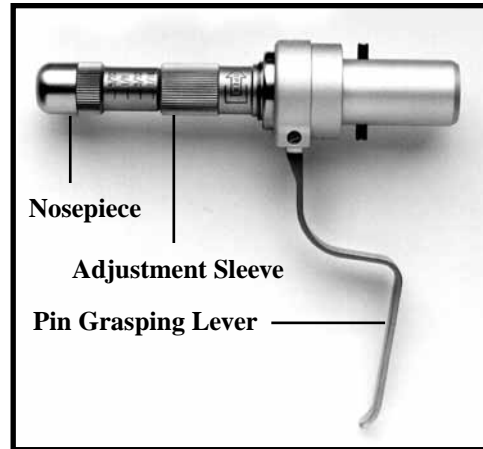

The Automatic Pin Driver is designed to drive pins (wires) and drill bits compatible with the specifications below:

Through Cannulation: 1.6 - 4.0 mm
(0.062 in to 0.156 in.)
(1/16 - 5/32 in.)

1. To insert a pin:
 - (a) Ensure the handpiece is in the safe position before inserting or removing a pin.
 - (b) Rotate the adjustment sleeve until the desired pin size graduation appears on the shaft of the nosepiece. Do not turn the adjustment sleeve more than one turn past the marked graduation limits.

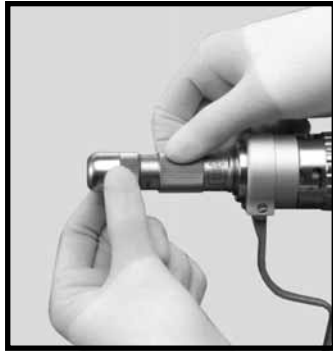

- (c) Insert the pin. While holding the nosepiece, tighten the adjustment sleeve until the pin is held firmly in place.

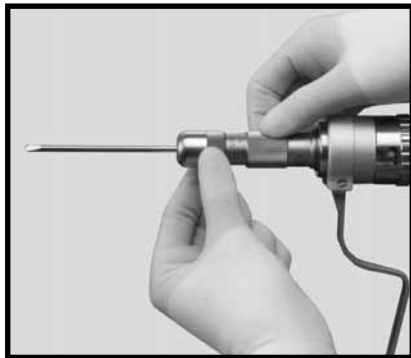

- (d) Loosen the adjustment sleeve one half turn. The pin should slide freely within the Pin Driver until the grasping lever is depressed.

- (e) For pin sizes that fall between the pin size graduation, loosen the adjustment sleeve one full turn. The pin should slide freely within the Pin Driver until the grasping lever is depressed.
2. To operate the handpiece:
 - (a) Release the safety and place the handpiece in the forward position.
 - (b) To grip and drive the pin, depress the grasping lever until flush with the handpiece and depress the trigger.
3. To reposition the handpiece on the pin:
 - (a) Release the trigger and grasping lever.
 - (b) Slide the handpiece along the pin.
 - (c) Follow step 2 to further drive the pin.

2.2.3 Oscillating Saw Attachment (L320A)



Specifications:

Blade Excursion Arc: 4-1/2° arc

NOTES:

1. The L320A Oscillating Saw attachment accepts “L” series blades.
2. For more precise osteotomies, lower cutting temperatures, and reduced instrument wear, use a new blade for each procedure.
3. Oscillating Saw blades are single-use only. Dispose of properly after use.



1. To attach the Oscillating Saw attachment, reference “2.2.1 Connecting/Removing Attachments” on page 9.

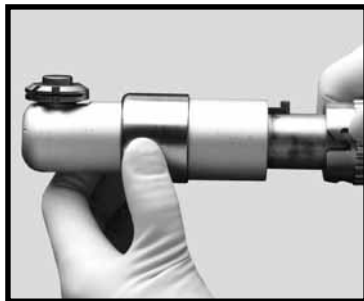

2. The Oscillating Saw attachment may be placed in any of four positions at 90 degree angles.
3. To attach a blade:
 - (a) Ensure the handpiece is in the safe position before attaching or removing blades.
 - (b) While depressing the blade locking button on the attachment, insert the blade in the desired position. Release the locking button. The blade is correctly seated when the locking button clicks up into place.

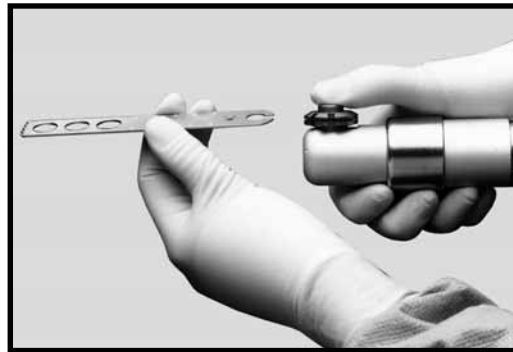

- (c) Ensure the blade is secured by pulling outward on the blade.
4. The blade may be placed in five positions within a 180 degree radius.
 5. To remove a blade:
 - (a) Ensure the handpiece is in the safe position.
 - (b) Depress the center retaining button, pull the blade forward and lift the blade off the pins.

2.2.4 Reciprocating Saw Attachment (L140A)



Specifications:

Blade Stroke Length: 6.3 mm (0.25 in.)

NOTES:

1. The L140A Reciprocating Saw attachment accepts “P” series blades.
2. For more precise osteotomies, lower cutting temperatures, and reduced instrument wear, use a new blade for each procedure.
3. Reciprocating Saw blades are single-use only. Dispose of properly after use. 

1. To attach the Reciprocating Saw attachment, reference “2.2.1 Connecting/Removing Attachments” on page 9.
2. The Reciprocating Saw attachment may be placed in any of four positions at 90 degree angles.
3. To attach a blade:
 - (a) Turn the twist-lock collar counter-clockwise.

- (b) Insert the blade into the blade holder in the desired blade position. Blades may be placed in either of two positions, with the cutting edge facing up or down.

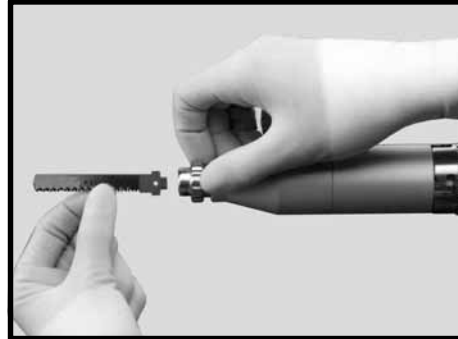

- (c) Release the twist-lock collar. Ensure the blade is secured by pulling outward on the blade.
4. To remove a blade:
 - (a) Ensure the handpiece is in the safe position. 
 - (a) Turn the twist-lock collar counter-clockwise and remove the blade.

2.2.5 Jacobs Chuck Attachment (L110)

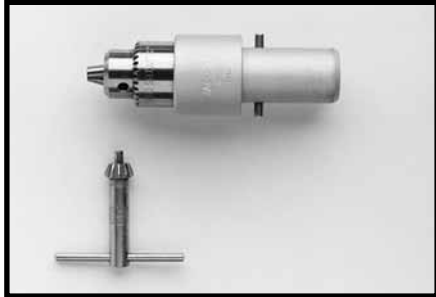

CAUTION: Do Not use burs in any Jacobs Chuck attachment.

This attachment is designed to drive plain shank drill bits, pins, and other accessories compatible with the specifications below:

Specifications:

Jaw Cannulation: 0 - 6.35 mm
(0 to 0.250 in.)
(0 to 1/4 in.)

Through Cannulation: 6.35 mm (0.250 in.)
(1/4 in.)

Associated Chuck Key: REF D298L and
5044-999-52

1. To attach the Jacobs Chuck attachment, reference “2.2.1 Connecting/Removing Attachments” on page 9).
2. Insert the desired accessory into the chuck and secure it with the Chuck Key (D298L).

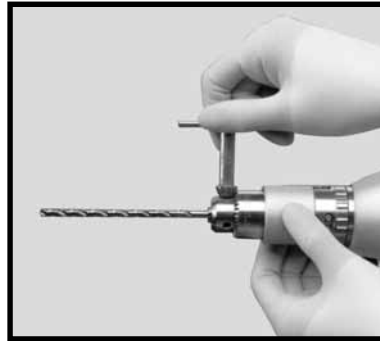

2.2.6 Trinkle Chuck Attachment (L112)



This attachment is designed to drive drill bits, automatic screwdrivers, and other accessories with Trinkle fittings.

Specifications:

Through Cannulation: 4.8 mm (0.187 in.)
(3/16 in.)

1. To attach a Trinkle Chuck attachment, reference **“2.2.1 Connecting/Removing Attachments” on page 9**.
2. To insert a Trinkle Shank accessory into the Trinkle Chuck attachment:
 - (a) Pull the locking sleeve chuck back. Insert the accessory and release the locking sleeve.
 - (b) Turn the accessory in the chuck until it locks.

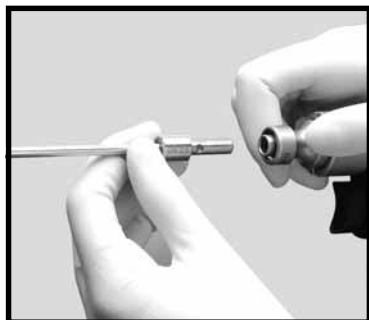

- (c) Ensure the accessory is securely seated in the attachment before use by pulling outward on it.
3. To remove accessory, pull back the locking sleeve chuck and remove the accessory.

2.2.6.1 Automatic Screwdrivers for the Trinkle Chuck Attachment (D520/D524)

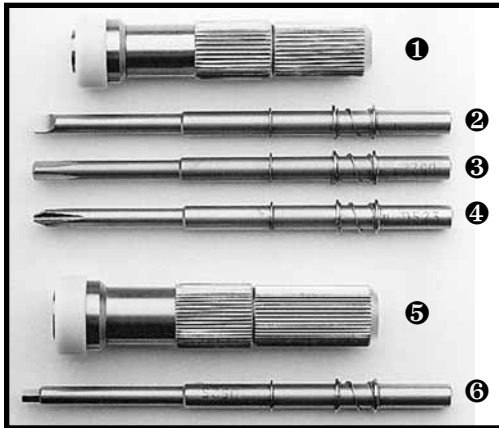

- ❶ Screwdriver (D520)
- ❷ Slotted Bit (D521)
- ❸ Cruciate Bit (D522)
- ❹ Phillips Bit (D523)
- ❺ Screwdriver (D524)
- ❻ Hex Bit for AO type screws (D525)

1. To insert a bit into the screwdriver.
 - (a) Unscrew the bit retainer section (counterclockwise) from the screwdriver.
 - (b) Insert the bit into the back of the screwdriver, tip first.

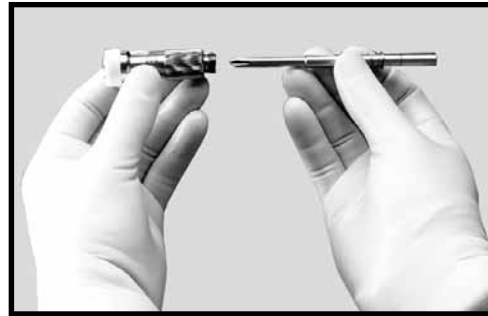

- (c) Slide the bit retainer over the bit and thread the retainer back on the screwdriver by turning it clockwise until tight.



- (d) While retracting the locking sleeve on the Trinkle Chuck attachment, insert the screwdriver into the chuck and release the locking sleeve.
- (e) Turn the accessory in the chuck until it locks.

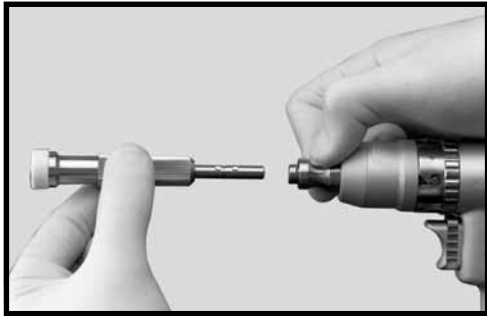

- (f) Ensure the attachment is secure by pulling outward on it.

CAUTION: Ensure that the screwdriver is securely seated in the Trinkle Chuck before use.

- 2. To engage the screwdriver bit into the screw head.
 - (a) Insert the head of the screw into the screwdriver.
 - (b) Hold the screw firmly and press the knurled portion of the screwdriver body forward so the teflon collar snaps over the head of the screw.

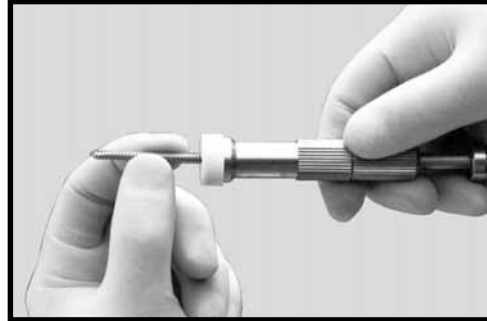

- 3. To remove the screw, retract the teflon collar and remove the screw.

2.2.7 Hudson Chuck Attachment (L113)



This attachment is designed to drive intramedullary reamers and other accessories with Hudson fittings.

Specifications:

Through Cannulation: 4.8 mm (0.187 in.)
(3/16 in.)

1. To attach a Hudson Chuck attachment, reference **“2.2.1 Connecting/Removing Attachments” on page 9**).
2. To insert a Hudson Shank accessory into the Hudson Chuck attachment:
 - (a) Pull the locking sleeve chuck back. Insert the accessory and release the locking sleeve.

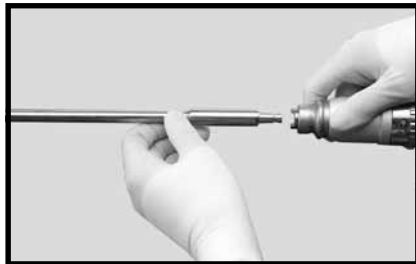

- (b) Ensure the accessory is securely seated in the attachment before use.

CAUTION: Operating the intramedullary flexible reamer in reverse may cause the reamer to jam in the intramedullary canal or damage the reamer shaft.

3. To remove the accessory, pull back the locking sleeve of the chuck and remove the accessory.

2.2.8 Hudson Reamer Drive Attachment (L150)



This attachment is designed to drive acetabular or intramedullary (flexible or rigid) reamers with Hudson fittings.

Specifications:

Through Cannulation: 4.8 mm (0.187 in.)
(3/16 in.)

1. To attach a Hudson Reamer Drive attachment, reference “2.2.1 Connecting/Removing Attachments” on page 9).
2. If desired, slide the Holding Handle (L296) accessory over the Reamer Drive attachment. Secure the Holding Handle accessory in the desired position by turning the handle clockwise until tight.

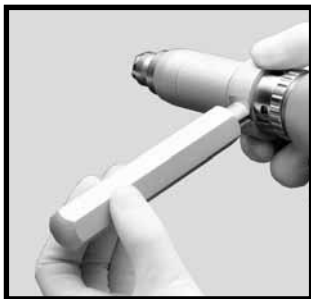

3. To insert a Hudson Shank accessory into the Hudson Reamer Drive attachment:
 - (a) Pull the locking sleeve chuck back. Insert the accessory and release the locking sleeve.

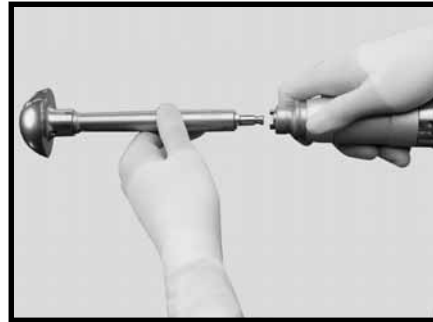

- (b) Ensure the accessory is securely seated in the attachment before use.

CAUTION: Operating the intramedullary flexible reamer in reverse may cause the reamer to jam in the intramedullary canal or damage the reamer shaft.

4. To remove the accessory, retract the locking sleeve of the chuck and remove the accessory.

2.2.9 Zimmer Chuck Attachment (L115)



This attachment is designed to drive flexible or rigid reamers with Zimmer-type fittings.

Specifications:

Through Cannulation: 4.8 mm (0.187 in.)
(3/16 in.)

1. To attach a Zimmer Chuck attachment, reference “**2.2.1 Connecting/Removing Attachments**” on page 9).
2. To insert a Zimmer Shank accessory into the Zimmer Chuck attachment:
 - (a) Pull the locking sleeve chuck back. Insert the accessory and release the locking sleeve.

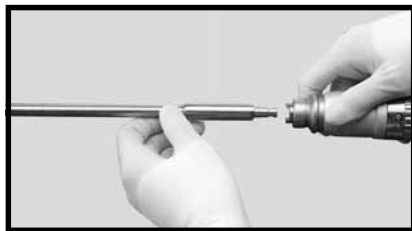

- (b) Ensure the accessory is securely seated in the attachment before use.

CAUTION: Operating the intramedullary flexible reamer in reverse may cause the reamer to jam in the intramedullary canal or damage the reamer shaft.

3. To remove the accessory, retract the locking sleeve of the chuck and remove accessory.

2.2.10 Zimmer Reamer Drive Attachment (L153)



This attachment is designed to drive acetabular or intramedullary (flexible or rigid) reamers with Zimmer-type fittings.

Specifications:

Through Cannulation: 4.8 mm (0.187 in.)
(3/16 in.)

1. To attach a Zimmer Reamer Drive attachment, reference **“2.2.1 Connecting/Removing Attachments” on page 9**).
2. If desired, slide the Holding Handle (L296) accessory over the Reamer Drive attachment. Secure the Holding Handle accessory in the desired position by turning the handle clockwise until tight.

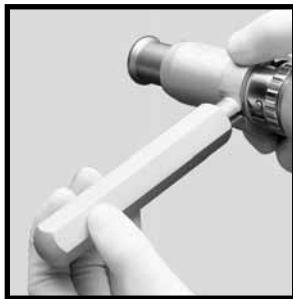

3. To insert a Zimmer Shank accessory into the Zimmer Reamer Drive attachment:
 - (a) Pull the locking sleeve chuck back. Insert the accessory and release the locking sleeve.

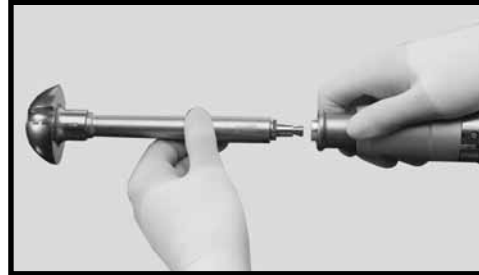

- (b) Ensure the accessory is securely seated in the attachment before use.

CAUTION: Operating the intramedullary flexible reamer in reverse may cause the reamer to jam in the intramedullary canal or damage the reamer shaft.

4. To remove the accessory, retract the locking sleeve of the chuck and remove the accessory.

2.2.11 ASIF/AO Twist Drill Chuck Attachment (L513)



This attachment is designed to drive drill bits with ASIF/AO (Synthes) type fittings.

Specifications:

Through Cannulation: 4.8 mm (0.187 in.)
(3/16 in.)

1. To attach an ASIF/AO Twist Drill Chuck attachment, reference “**2.2.1 Connecting/ Removing Attachments**” on page 9).
2. To insert an ASIF/AO drill bit into the ASIF/AO Twist Drill Chuck attachment:
 - (a) Pull the locking sleeve chuck back. Insert the accessory and release the locking sleeve.

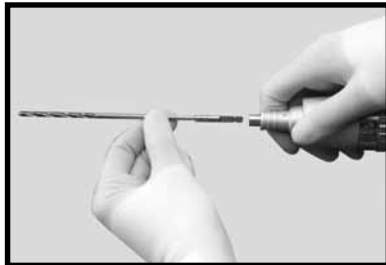

- (b) Ensure the accessory is securely seated in the attachment before use.
3. To remove the accessory, retract the locking sleeve of the chuck and remove accessory.

2.2.12 ASIF/AO Flexible Chuck Attachment (L514)



This attachment is designed to drive intramedullary (flexible or rigid) reamers with ASIF/AO (Synthes) type fittings.

Specifications:

Through Cannulation: 4.8 mm (0.187 in.)
(3/16 in.)

1. To attach an ASIF/AO Flexible Chuck attachment, reference “**2.2.1 Connecting/Removing Attachments**” on page 9).
2. To insert an ASIF/AO accessory into the ASIF/AO Flexible Chuck attachment:
 - (a) Pull the locking sleeve chuck back. Insert the accessory and release the locking sleeve.

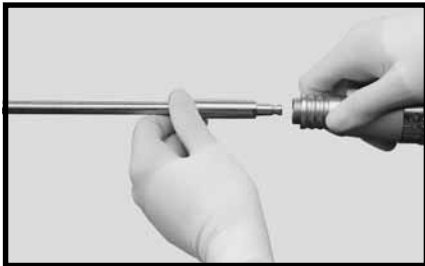

- (b) Ensure the accessory is securely seated in the attachment before use.

CAUTION: Operating the intramedullary flexible reamer in reverse may cause the reamer to jam in the intramedullary canal or damage the reamer shaft.

3. To remove the accessory, retract the locking sleeve of the chuck and remove the accessory.

2.2.13 ASIF/AO Reamer Drive Attachment (L151)



This attachment is designed to drive acetabular or intramedullary (flexible or rigid) reamers with ASIF/AO (Synthes) type fittings.

Specifications:

Through Cannulation: 4.8 mm (0.187 in.)
(3/16 in.)

1. To attach an ASIF/AO Reamer Drive attachment, reference “**2.2.1 Connecting/Removing Attachments**” on page 9).
2. If desired, slide the Holding Handle (L296) accessory over the Reamer Drive attachment. Secure the Holding Handle accessory in the desired position by turning the handle clockwise until tight.

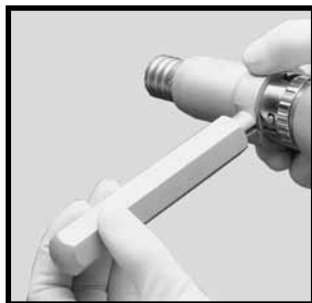

3. To insert an ASIF/AO accessory into the ASIF/AO Reamer Drive attachment:
 - (a) Pull the locking sleeve chuck back. Insert the accessory and release the locking sleeve.

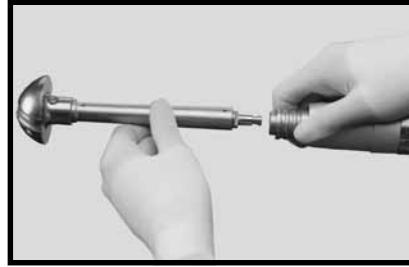

- (b) Ensure the accessory is securely seated in the attachment before use.

CAUTION: Operating the intramedullary flexible reamer in reverse may cause the reamer to jam in the intramedullary canal or damage the reamer shaft.

4. To remove the accessory, retract the locking sleeve of the chuck and remove the accessory.

2.2.14 Aesculap Reamer Drive Attachment (L152)



This attachment is designed to drive acetabular or intramedullary (flexible or rigid) reamers with Aesculap fittings.

Specifications:

Through Cannulation: 4.8 mm (0.187 in.)
(3/16 in.)

1. To attach an Aesculap Reamer Drive attachment, reference “**2.2.1 Connecting/Removing Attachments**” on page 9).
2. If desired, slide the Holding Handle (L296) accessory over the Aesculap Reamer Drive attachment. Secure the Holding Handle accessory in the desired position by turning the handle clockwise until tight.

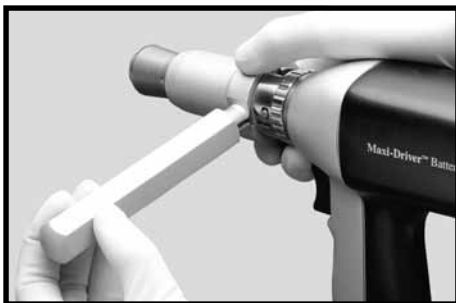

3. To insert an Aesculap accessory into the Aesculap Reamer Drive attachment:
 - (a) Pull the locking sleeve chuck back. Insert the accessory and release the locking sleeve.

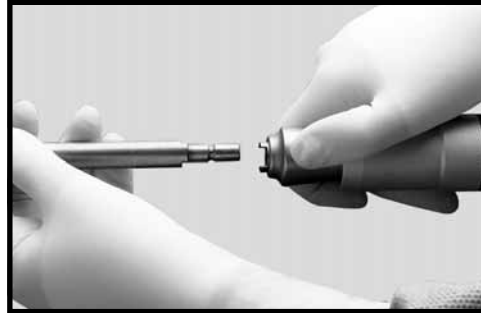

- (b) Ensure the accessory is securely seated in the attachment before use.

CAUTION: Operating the intramedullary flexible reamer in reverse may cause the reamer to jam in the intramedullary canal or damage the reamer shaft.

4. To remove the accessory, retract the locking sleeve of the chuck and remove the accessory.

2.2.15 Aesculap Chuck Attachment (L515)



This attachment is designed to drive intramedullary reamers and other accessories with Aesculap fittings.

Specifications:

Through Cannulation: 4.8 mm (0.187 in.)
(3/16 in.)

1. To attach an Aesculap Chuck attachment, reference “**2.2.1 Connecting/Removing Attachments**” on page 9).
2. To insert an Aesculap accessory into the Aesculap Chuck attachment:
 - (a) Pull the locking sleeve chuck back. Insert the accessory and release the locking sleeve.

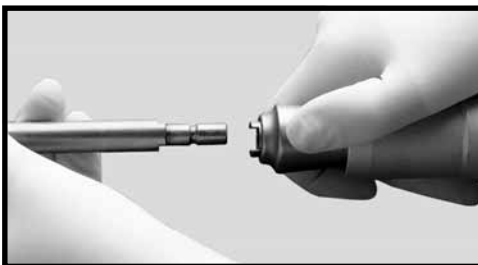

- (b) Ensure the accessory is securely seated in the attachment before use.

CAUTION: Operating the intramedullary flexible reamer in reverse may cause the reamer to jam in the intramedullary canal or damage the reamer shaft.

3. To remove accessory, retract the locking sleeve of the chuck and remove accessory.

3.0 MAINTENANCE

This section explains the importance of keeping your Maxi-Driver Pneumatic System well maintained. It contains a maintenance schedule to assist you in determining the maintenance interval requirements of your instruments.

Regular and proper maintenance of your powered surgical instruments are the best way to protect your investment. It is essential that you have your powered surgical instruments serviced as scheduled so as to retain their optimum performance and reliability, which will reward you with safer, less problematic product performance over time. The following maintenance schedule specifies which instruments need attention and how often you should have them serviced.

The service and time intervals shown in the maintenance schedule assume you will use the instruments as indicated in this manual, including proper day-to-day operation, cleaning, and sterilization. Proper care and handling of the instruments on a day-to-day basis are extremely important to ensure safe and efficient operation. Refer to section 2.0 of this instruction manual for information on proper system installation and operation and section 3.0 for proper day-to-day maintenance.



Your authorized Linvatec Service Department is the most knowledgeable about the instruments and will provide competent and efficient service. Service at Linvatec at the indicated service intervals is mandatory to keep your product warranties in effect. Any services and/or repairs done by any unauthorized repair facility may result in reduced performance of the instruments or instrument failure and is not recommended. See **“5.3 Linvatec and Hall® Surgical Instrument Warranty” on page 42** for more information on product warranties.

Table 1: Maintenance Schedule

Catalog Number	Product Description	6 Months	12 Months
L100	Maxi-Driver Pneumatic Handpiece		•
L110	Jacobs Chuck Attachment		•
L111	Automatic Pin Drive Attachment		•
L112	Trinkle Chuck Attachment		•
L113	Hudson Chuck Attachment		•
L115	Zimmer Chuck Attachment		•
L140	Reciprocating Saw Attachment		•
L150	Hudson Reamer Drive Attachment		•
L151	ASIF/AO Reamer Drive Attachment		•
L152	Aesculap Reamer Drive Attachment		•
L153	Zimmer™ Reamer Drive Attachment		•
L320A	Oscillating Saw Attachment		•
L513	ASIF/AO Twist Drill Chuck Attachment		•
L514	ASIF/AO Chuck Attachment		•
L515	Aesculap Chuck Attachment		•
D520/D524	Automatic Screwdriver Attachments		•

3.1 Cleaning and Sterilizing

3.1.1 Cleaning Precautions

1. Follow universal precautions for protective apparel when handling and cleaning contaminated instruments.
2. Saw blades are single-use only. Dispose of properly after use. 
3. **Never immerse handpiece, pressure regulator, or attachments.** 
4. Never sterilize the regulator. 
5. Never clean handpieces with bleach, chlorine-based detergents, liquid or chemical disinfectants, or any products containing sodium hydroxide (i.e., INSTRU-KLENZ, Buell Cleaner). They will degrade the anodized aluminum coating.
6. Do not allow any fluids such as water or Blitz™ II Surgical Instruments Cleaner and Lubricant (M105A) to enter handpiece. Fluid contacting internal parts will cause corrosion. Surface cleaning with Blitz™ II Cleaner is recommended.
7. Never clean equipment in an ultrasonic cleaner or combination washer/sterilizer.

3.1.2 Handpiece and Attachment Cleaning Instructions

Clean the handpieces and attachments as soon as possible after use.

1. Leave the hose attached to the handpiece, but remove all attachments (i.e., chucks, saws) and accessories (i.e., saw blades, bits) prior to cleaning.
2. Thoroughly scrub handpiece with a clean, soft brush dampened with a mild, pH-balanced detergent. Likewise, clean the handpiece hose and attachments. Remove all traces of blood, coagulated material, stains, etc. **Do not immerse** equipment in soap solution or rinse water.
3. Thoroughly clean the cannulation with a cleaning brush. Feed the wire end of the brush through the back of the handpiece. Repeat until all debris is removed.
4. Manipulate all moving parts of the handpiece and attachments to ensure all debris is removed. If not, clean again until all debris is removed.
5. Keep the nose of the handpiece pointed downward and rinse under a fine spray of water to remove all traces of soap. Likewise, rinse all attachments. Flush the surfaces free of tap water with distilled water to prevent metal discoloration.
6. Shake the equipment free of water and wipe the surfaces with a clean, lint-free towel.

3.1.3 Handpiece and Attachment Lubrication Instructions

1. Spray Blitz II Surgical Instruments Cleaner and Lubricant liberally over exposed surfaces of handpiece and attachments, especially all moving parts.

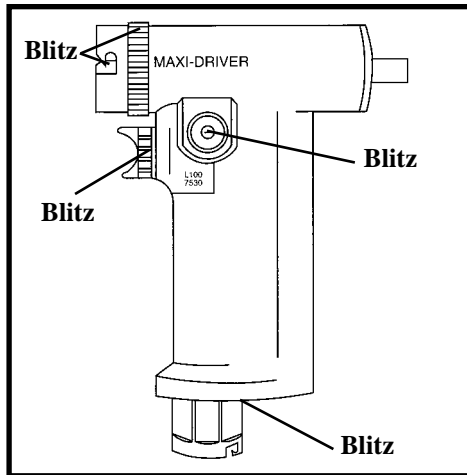

2. Wipe the surfaces with a clean, lint-free towel.

3. Disconnect the hose from the handpiece. While depressing the trigger, apply three (3) drops of Lubricant (M317) into the handpiece standpipe.

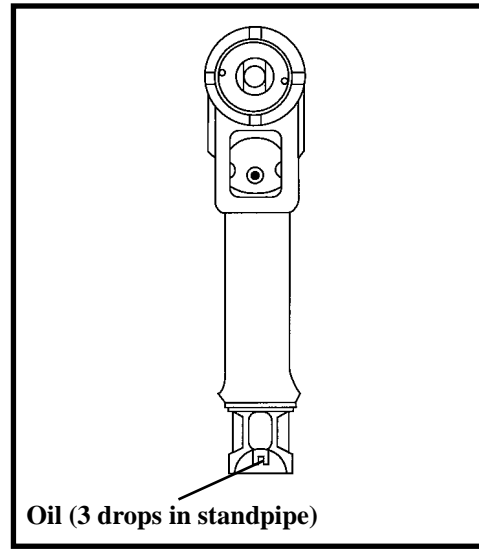

4. Reconnect the hose to the handpiece and operate at full speed for five seconds to disperse lubricant.

3.1.4 Sterilization Information

Steam sterilization is safe and effective and has no contraindications for its use in sterilizing powered surgical handpieces, accessories and attachments.

3.1.4.1 Sterilization Warnings, Precautions and Notes

WARNING: The use of disinfecting solutions for an exterior instrument wipe will not sterilize equipment and is not recommended.

1. Do not sterilize with Ethylene Oxide (EtO).
2. Do not sterilize handpieces or attachments in cold sterilants like CIDEX.
3. Never sterilize any handpiece in a Washer/Sterilizer, STERIS System, STERRAD System, Abtox Plazlyte™ or comparable sterilization methods.
4. Do Not “Peel Pack” handpieces or attachments for sterilization. Sterilization in a sealed pouch traps moisture which can cause damage.
5. Remove the hose from the handpiece before sterilizing.
6. Use of an autoclave case is recommended.
7. Do not run handpieces while warm. Allow adequate time for cooling prior to surgery. Do not immerse in liquid or cover with a damp cloth to cool. Cool by exposure to room temperature.

NOTES:

1. **The following guidelines do not guarantee the device is sterile after the procedure. Your institution is still responsible for the normal sterility assurance validation.**
2. **Additional drying time may be required for complete heat and moisture dissipation. Operation of a handpiece that is not completely cool or dry may decrease performance and/or reliability**
3. **Sterilization validation is based on AAMI guidelines (Association for the Advancement of Medical Instrumentation).**

All handpieces and attachments may be processed in a pre-vacuum steam sterilizer (Steam Pre-vacuum) or in a gravity (downward) displacement sterilizer (Steam Gravity).

Before Sterilization:

- Remove all accessories (e.g., drill bits, blades) from attachments.
- Remove all attachments (e.g., chucks, saws, and/or hoses) from the handpiece.
- Ensure all attachments were cleaned.
- Lubricate, as necessary, equipment requiring lubrication, per guidelines in “**3.1.2 Handpiece and Attachment Cleaning Instructions**” on page 28, prior to sterilization.

Recommended sterilization exposure times of individual handpieces and attachments are as follows:

Table 2: Sterilization Parameters

Sterilization Type	Temperature	Exposure Time	Dry Time
Maxi-Driver Handpieces and Attachments			
Steam Pre-vacuum	270 - 272°F (132 - 133°C)	4 minutes	8 minutes minimum *
Steam Gravity	270 - 272°F (132 - 133°C)	25 minutes	8 minutes minimum *
Steam Gravity	250 - 254°F (121 - 123°C)	50 minutes	8 minutes minimum *
<p>* CAUTION: An eight (8) minute minimum dry cycle must be run on handpieces and attachments every time the product is sterilized. Failure to use a dry cycle may lead to reduced product performance or premature product failure. Operation of a handpiece that is not completely cool or dry may decrease performance and/or reliability.</p>			

3.2 Troubleshooting

Table 3: Troubleshooting

Symptom	Possible Cause	Corrective Action
Maxi-Driver Pneumatic (L100) Handpiece		
Lack of handpiece power.	<ul style="list-style-type: none"> ◆ Forward/Reverse button not in full operating position. ◆ Regulator malfunction. ◆ Operating pressure incorrect. ◆ Hose not fully or properly seated in regulator and/or handpiece. ◆ Restrictions in hose. ◆ Tank pressure below 500 psi. ◆ Tank valve not completely open. ◆ Ensure nitrogen is being used. 	<ul style="list-style-type: none"> ◆ Push button fully into position. ◆ Run handpiece on another regulator to see if the problem is the handpiece or regulator. Replace/repair appropriate piece of equipment. ◆ Set pressure to recommended operating pressure. ◆ If using an extension hose or a hose longer than 10 ft., add an additional one psi of pressure per each additional foot of hose. ◆ Check hose connections, ensure they are completely seated. ◆ Remove any hose restrictions. ◆ Do not start procedure if tank pressure is below 500 psi. Replace tank. ◆ Completely open tank valve. ◆ Compressed air (especially if contaminated) may reduce performance.

Table 3: Troubleshooting

Symptom	Possible Cause	Corrective Action
Maxi-Driver Pneumatic (L100) Handpiece (continued)		
Lack of handpiece power (continued).	<ul style="list-style-type: none"> ◆ Lack of lubrication in motor. 	<ul style="list-style-type: none"> ◆ Follow lubrication instructions (reference “3.1.2 Handpiece and Attachment Cleaning Instructions” on page 28). ◆ If malfunction persists, return for service.
Excessive noise and heat.	<ul style="list-style-type: none"> ◆ Debris lodged in motor. ◆ Lack of lubrication. ◆ Worn bearings 	<ul style="list-style-type: none"> ◆ Clean and/or lubricate the handpiece according to “3.1.2 Handpiece and Attachment Cleaning Instructions” on page 28. ◆ Clean and/or lubricate the handpiece according to “3.1.2 Handpiece and Attachment Cleaning Instructions” on page 28. ◆ Return handpiece for service.
Forward/Reverse button stuck.	<ul style="list-style-type: none"> ◆ Debris lodged around button. 	<ul style="list-style-type: none"> ◆ Apply Blitz II Cleaner and Lubricant or M317 Lubricant and work back and forth.
Hose leaking at hose/handpiece connection.	<ul style="list-style-type: none"> ◆ Missing or worn O-Ring on hose connector. 	<ul style="list-style-type: none"> ◆ Replace O-Ring (REF 8016).

Table 3: Troubleshooting

Symptom	Possible Cause	Corrective Action
Maxi-Driver Pneumatic (L100) Handpiece (continued)		
Air leakage between air control dial and hose swivel connector of handpiece.	<ul style="list-style-type: none"> ◆ Debris around ball seal of hose connector at handpiece end. 	<ul style="list-style-type: none"> ◆ Remove hose. Depress and spray ball seal with Blitz II Cleaner and Lubricant. Reconnect hose. ◆ If problem persists, replace hose.
Hose has tears and/or cuts.	<ul style="list-style-type: none"> ◆ Improper storage. 	<ul style="list-style-type: none"> ◆ Replace hose. ◆ To prevent recurrence, disconnect hose from handpiece before placing in autoclave case. ◆ When placing in case, take care not to pinch hose. ◆ Return hose for repair or replace hose.
All Attachments		
Attachments do not lock into handpiece.	<ul style="list-style-type: none"> ◆ Attachment not oriented correctly. ◆ Debris in handpiece locking collar or in attachment. ◆ Attachment and/or handpiece bent. 	<ul style="list-style-type: none"> ◆ Will only attach in correct position (reference “2.2.1 Connecting/Removing Attachments” on page 9). ◆ Clean thoroughly with Blitz II Cleaner and Lubricant (reference “3.1.2 Handpiece and Attachment Cleaning Instructions” on page 28). ◆ Return for service.

Table 3: Troubleshooting

Symptom	Possible Cause	Corrective Action
Automatic Pin Driver		
Will not adjust to hold pins.	<ul style="list-style-type: none"> ◆ Internal debris. Possibly immersed in fluid. ◆ Adjustment sleeve rotated more than one turn past graduation limits. 	<ul style="list-style-type: none"> ◆ Return for service.
Excessive noise or heat.	<ul style="list-style-type: none"> ◆ Worn or dry bearings. 	<ul style="list-style-type: none"> ◆ Clean and/or lubricate the hand-piece according to “3.1.2 Hand-piece and Attachment Cleaning Instructions” on page 28. ◆ Return for service.
Reamer Drives or Chuck Attachments		
Chucks are stuck, sleeves will not retract.	<ul style="list-style-type: none"> ◆ Dried blood or debris lodged in chuck. 	<ul style="list-style-type: none"> ◆ Clean and/or lubricate the hand-piece according to “3.1.2 Hand-piece and Attachment Cleaning Instructions” on page 28. ◆ Return for service.
Oscillating Saw Attachments		
Blade does not cut properly.	<ul style="list-style-type: none"> ◆ Dull blade. 	<ul style="list-style-type: none"> ◆ Use a new blade for each procedure. Cut with light pressure and steady oscillation of blade.

Table 3: Troubleshooting

Symptom	Possible Cause	Corrective Action
Oscillating Saw Attachments (continued)		
<p>Blade difficult to insert or remove from saw.</p>	<ul style="list-style-type: none"> ◆ Trying to insert a non-Linvatec approved blade. ◆ Debris lodged in blade holder. Blade locking button jammed. 	<ul style="list-style-type: none"> ◆ Use Linvatec approved blades only. ◆ Clean thoroughly with Blitz II Cleaner and Lubricant to remove debris (see “3.1.2 Handpiece and Attachment Cleaning Instructions” on page 28). ◆ Return for service.
<p>Handpiece/attachment stops operating/sawing.</p>	<ul style="list-style-type: none"> ◆ Loose handpiece/cord connection. 	<ul style="list-style-type: none"> ◆ Reconnect cord to handpiece if sterility is not compromised. ◆ Oscillating Saw should not be used in a vertical orientation with the Maxi-Driver Electric handpiece. ◆ Use only Maxi-Driver Battery or Pneumatic handpiece for procedures requiring an oscillating saw in a vertical orientation.

Table 3: Troubleshooting

Symptom	Possible Cause	Corrective Action
Reciprocating Saw Attachment		
Blade does not cut properly	<ul style="list-style-type: none"> ◆ Dull blade. 	<ul style="list-style-type: none"> ◆ Use a new blade for each procedure. Cut with light pressure and steady oscillation of blade.
Blade difficult to insert or remove from saw.	<ul style="list-style-type: none"> ◆ Debris lodged in twist-lock collar. ◆ Collar may be bent. 	<ul style="list-style-type: none"> ◆ Clean and/or lubricate the hand-piece according to “3.1.2 Hand-piece and Attachment Cleaning Instructions” on page 28. ◆ Return for service.

4.0 TECHNICAL SPECIFICATIONS

Linvatec Corporation is certified by TÜV Product Service to EN ISO 9001 and EN 46001, and to the Medical Device Directive 93/42/EEC with certificates for Annex II, Clause 3; Annex II, section 4; and Annex V.

4.1 Handpiece

Typical Operating Requirements:

Motor:	Vane (Variable Speed)
Through Cannulation:	6.5 mm (0.255 in.)
Forward/Reverse:	0 - 950 rpm
Operating Pressure:	760 kPa (110 psi)
Nitrogen Consumption:	12 scfm (0.0057 m ³ /sec.)
Torque:	28 in-lbf (3.16 N-m)
Weight:	37 oz. (1052 g)
Material:	Aluminum and Stainless Steel

NOTE: There are no toxic components used in the manufacture of the Maxi-Driver Pneumatic System. After the useful life of the product, dispose of components and service parts properly.

4.2 System Environmental Requirements

Operating:

Ambient Operating Temperature:	+ 50°F to 77°F (+ 10°C to + 25°C)
Relative Humidity:	30% to 75%
Atmospheric Pressure:	700 hPa to 1060 hPa

Transport and Storage:

Ambient Temperature:	- 40°F to 158°F (- 40°C to + 70°C)
Relative Humidity:	10% to 100% including condensation
Atmospheric Pressure:	500 hPa to 1060 hPa

5.0 CUSTOMER SERVICE and WARRANTY

5.1 Customer Service

If you need technical assistance regarding the use or application of this product, or you encounter a problem that requires servicing or repair, contact Linvatec Customer Service at 800-925-4255 or your Hall Surgical Sales Representative. Outside the U.S. contact your Linvatec/Hall Representative.

Report any events involving injuries or malfunctions to the Linvatec Regulatory Affairs Department.

Returning products for any reason requires a Return Goods (R.G.) number that can be obtained by contacting Linvatec Customer Service. Please provide the following information:

- Product Number
- Serial/Lot Number
- Reason for Return
- Original Invoice Number
- Date of Purchase

Repairs

Products returned for repair must have an authorized Return Goods (R.G.) number prominently displayed on the box and included on all paperwork. Refer to this number if making inquiries about the repair status. Please call Linvatec Customer Service and provide the following information to obtain an R.G. number prior to returning any product for repair:

- Product Number
- Serial/Lot Number - if applicable
- Original Invoice Number
- Date of Purchase
- Detailed description of the problem
- Purchase Order Number

If you require a quote - Notify Customer Service when requesting your R.G. number, or on the paperwork returned with the product indicate that a quote is required. If a quote is not requested the repair will be processed and your account billed accordingly - provided the repair is not covered under warranty.

Minimum repair charge - There is a minimum repair charge (except for products covered under warranty). This charge also applies to products returned for repair in which a problem cannot be verified.

Whenever it is required to return your product for repairs, be sure to package it in a protective carton. We recommend that you save the original shipping container for this purpose. In-transit damage is not covered by the warranty, therefore, it is best to always insure shipments.

Returned Goods

Products must be returned within 45 days of ship date. Returned products are subject to a restocking fee of fifteen percent (15%) of the purchase price (minimum charge \$25). Products returned as a result of errors attributable to Livatec are exempt from this fee.

Returns must have an authorized Return Goods (R.G.) number prominently displayed on the box and included on all paperwork.

Returns must be shipped prepaid freight, otherwise they will not be accepted. **Products must be decontaminated and sterilized before returning. Products that are contaminated with biohazardous materials will be immediately returned to you for proper decontamination and sterilization.**

Livatec

**Attn.: Customer Service Dept.
11311 Concept Boulevard
Largo, Florida 33773-4908 USA**

Customer Service

(within U.S.)	Phone: 800-925-4255
	FAX: 727-399-5256
(outside U.S.)	Phone: 727-392-6464
	FAX: 727-397-4540

Livatec Regulatory Affairs

(within U.S.)	Phone: 800-237-0169
(outside U.S.)	Phone: 727-399-6620

5.2 Handpieces, Attachments and Accessories

<u>REF</u>	<u>Description</u>
	<u>Maxi-Driver Attachments and Accessories</u>
L100	Pneumatic Handpiece
D201	Universal Air Hose, 10 ft.
L110	Jacobs Chuck Attachment
L111	Automatic Pin Driver Attachment
L112	Trinkle Chuck Attachment
L113	Hudson Chuck Attachment
L115	Zimmer Chuck Attachment
L140	Reciprocating Saw Attachment
L150	Hudson Reamer Drive Attachment
L151	ASIF/AO Reamer Drive Attachment
L152	Aesculap Reamer Drive Attachment
L153	Zimmer Reamer Drive Attachment
L513	ASIF/AO Twist Drill Chuck Attachment
L514	ASIF/AO Chuck Attachment
L320A	Oscillating Saw Attachment
L515	Aesculap Chuck Attachment
D520	Automatic Screwdriver Attachment
D524	Automatic Screwdriver Attachment
D521	Slotted Bit
D522	Cruciate Bit
D523	Phillips Bit
D525	Hex Bit for AO type screws
M105A	Blitz II Surgical Instrument Cleaner and Lubricant
M317	Lubricant

5.3 Linvatec and Hall® Surgical Instrument Warranty

Linvatec Corporation, (“the Company”), warrants to the first purchaser or lessee (“Customer”) that the Linvatec and Hall Surgical instruments, attachments and parts manufactured by or for the Company (hereinafter collectively “Instruments”) have been tested, inspected, and shipped in proper working order.

The Company warrants all new Instruments to be free from defects in materials and workmanship for the following periods, measured from Customer’s receipt:

1. Powered Surgical Equipment (battery, electric, pneumatic) - Twelve (12) Months
2. Battery Chargers - Twelve (12) Months
3. Battery Packs - Three (3) Months
4. Burs and Blades - Upon receipt
5. Bur Guards, Blade Guards, and Attachments - Six (6) Months
6. Skull Perforators - Six (6) Months
7. Pneumatic Hoses - Six (6) Months
8. Handpiece Cords and Power Cords - Six (6) Months
9. Camera Consoles - Twenty-four (24) Months
10. Video Components - Twelve (12) Months
11. Video Cables and Light Guides - Three (3) Months
12. Non-autoclavable Camera Heads - Twelve (12) Months
13. APEX® Autoclavable Camera Heads - 500 use service program (prorated credit after 250 uses)
14. Envision 1/4” Autoclavable Camera Heads - 500 use or Twelve (12) months, whichever comes first
15. Envision Autoclavable 3CCD Camera Heads - Twelve (12) months
16. Shutt SLG Instruments - Lifetime
17. Shutt Non-SLG Instruments - Twelve (12) Months
18. Footswitches - Twelve (12) Months
19. Irrigation Systems - Twelve (12) Months
20. Reusable Procedure Specific Instruments - Twelve (12) Months

The Maxi-Driver handpiece and attachments described in this manual are to be returned to the factory or a Linvatec authorized service facility for routine maintenance according to the Maintenance Schedule Table starting on page 27.

Failure to follow this routine maintenance schedule may result in damage to the handpiece and/or console, and may invalidate the product warranty.

If within the specified warranty period the Customer discovers that an Instrument has a defect in material and/or workmanship, it must promptly notify the Company. If it becomes necessary to return the Instrument to the Company, the Customer must (a) acquire a “Returned Goods” authorization from the Company Customer Service, (b) pack the unit carefully, and (c) return it to the Company via air freight, pre-paid.

Within a reasonable time after receipt of Instrument, the Company will investigate and shall correct any defect covered by warranty by providing, at its option, one of the following: service or repair of the Instrument, a replacement of the Instrument, or a refund of the purchase price of the Instrument. These remedies are the Customer's exclusive remedies under this warranty.

The Company warrants that all parts and assemblies used in the repair or service of Instruments meet new part functional specifications, although some parts or assemblies may have been remanufactured.

All parts and assemblies replaced by the Company shall become the property of the Company.

The foregoing limited warranties do not apply to:

1. Instruments which have been tampered with, altered, abused or misused.
2. Instruments damaged through use with other than Company authorized accessories, attachments, burs or blades.
3. Instruments not manufactured by or for the Company.
4. Instruments used for purposes other than those for which they were designed and manufactured, including use in any way inconsistent with the instructions and warnings contained in the Company instruction manuals and package inserts.
5. Instruments which were last serviced, refurbished, reprocessed or reconditioned by a nonauthorized service entity.

6. Instruments which did not have their aforementioned routine maintenance schedule followed.

The foregoing limited warranties are in lieu of all other warranties, expressed or implied, including, but not limited to, the implied warranties of merchantability and fitness for a particular purpose.

Except claims for personal injury, in no case shall the Company be liable for any special, incidental or consequential damages based upon breach of warranty or any other legal theory. Some jurisdictions do not allow limits on warranties, or on remedies, and, in such jurisdictions, the limits in this and the preceding paragraphs may not apply.

The Company reserves the right (a) to make design changes to Instruments at anytime without notice to Customer and without incurring any obligation to incorporate those changes into Instruments previously purchased or leased, and (b) to make changes from time to time in the contents of any publication, instruction manual or package insert without any obligation to notify Customers of such revisions or changes.



11311 Concept Boulevard Largo, Florida 33773-4908

Phone: (727) 392-6464

Customer Service: (800) 925-4255

USA Fax: (727) 399-5256

International Fax: (727) 397-4540

www.linvatec.com

© 2001 Linvatec Corporation, a subsidiary of ConMed Corporation

All rights reserved. Printed in USA W41-062-004 Rev. A 08/2001